

## Basic Power Quality Methodology And Common Culprits

*Our thanks to Fluke Corp. for allowing us to reprint the following.*

While we've enjoyed enormous benefits from the evolution of solid state technology, the fact is that the microelectronics at the heart of that technology requires clean power. Faster speeds and lower voltages mean that there is less and less tolerance for anything less than quality power.

Power Quality (PQ) covers a wide range of issues, from voltage disturbances like sags, swells, outages and transients, to current harmonics, to performance wiring and grounding. The symptoms of poor PQ include intermittent lock-ups and resets, corrupted data, premature equipment failure, overheating of components for no apparent cause, etc. The ultimate cost is in downtime, decreased productivity and frustrated personnel.

### Start at the scene of the crime

To troubleshoot PQ problems, one approach is to start as close to the "victim load" as possible. The "victim load" is the sensitive load, typically electronic, that is somehow malfunctioning. Poor PQ is suspected, but part of your job is to *isolate* PQ as a cause from other possible causes (hardware, software?). Like any detective, you should start at the scene of the crime. This bottom-up approach can take you a long way. It relies on making use of a sharp eye and on taking some basic measurements. An alternative is to start at the service entrance, using a three-phase monitor, and work back to the "victim load." This is most useful if the

problems originate with the utility. Yet survey after survey has concluded that *the great majority of PQ problems originate in the facility*. In fact, as a general rule, PQ is best at the service entrance (connection to utility) and deteriorates as you move downstream through the distribution system. That's because the facility's own loads are causing the problems. Another illuminating fact is that *75 % of PQ problems are related to wiring and grounding problems!*

For this reason, many PQ authorities recommend that a logical troubleshooting flow is to first diagnose the electrical infrastructure of the building, then monitor if necessary. Our bottom-up troubleshooting procedure is designed to help you do this detective work.

### First steps

#### 1. Make a map: Obtain or create a current one-line

It's tough to diagnose PQ problems without having a working knowledge of the site being investigated. You can start by locating or reconstructing a one-line diagram of the site. The one-line will identify the ac power sources and the loads they serve. The "as built" one-line, the one with red-lines, is the one you want.

If you work on-site, the map might already exist in your head, but it will be a big help to everyone, including yourself, if it's on paper. If you're coming to a work site for the first time, getting an up-to-date one-line means identifying new loads or other recent changes in the system. Why go to this effort? Systems are dynamic; they change over time, often in unplanned and haphazard ways. Furthermore, while some problems are local in origin and effect, there are many problems that result from interactions between one part of the system and another. Your job is to understand these system interactions. The more complete your documentation, the better off you'll be.

It's true, however, that the sites that need the most help are the ones least likely to have a good record of what's going on in their system. Many a consultant has earned his fee by upgrading the documentation handed him with what actually exists on-site. So the simple rule is, at this point in the investigation, do the best you can to get good documentation, but don't count on it being available.

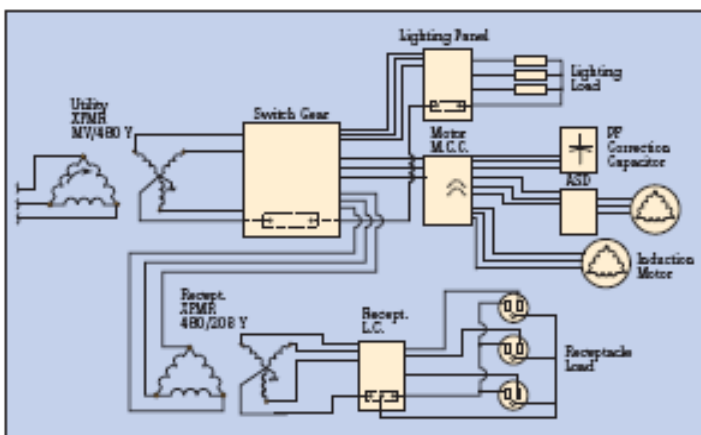

Figure 1 Simplified electrical distribution system typical of commercial and industrial facilities

## 2. Do a walk around of the site

Sometimes a visual inspection will offer immediate clues:

- A transformer that's much too hot
- Wiring or connections discolored from heat
- Receptacles with extension strips daisy-chained to extension strips
- Signal wiring running in the same trays as power cables
- Extra neutral-ground bonds in sub-panels.
- Grounding conductors connected to pipes that end in mid-air.

At a minimum, you will get a sense of how the facility is wired and what the typical loads are.

## 3. Interview affected personnel and keep an incident log

Interview the people operating the affected equipment. You will get a description of the problem and often turn up unexpected clues. It's also good practice to keep a record of when problems happen and what the symptoms are. This is most important for problems that are intermittent. The goal is to find some pattern that helps correlate the occurrence of the problem in the "victim load" to a simultaneous event elsewhere. Logically, this trouble-logging is the responsibility of the operator closest to the affected equipment.

### A Lineup of Power Quality Culprits From utility source to receptacle

#### Lightning

Can be extremely destructive if proper surge protection is not installed. It also causes sags and under-voltages on the utility line if far away. If close by, it causes swells and over-voltages. But in the final analysis, lightning is an act of nature and not in the same category as the damage man does to himself.

#### Utility automatic breaker reclosure

Causes short duration sags/outages, but better than the alternative, a longer-term outage.

#### Utility capacitor switching

Causes a high-energy voltage disturbance (looks like an oscillating transient riding on the wave). If the cap bank is near the facility, this transient can propagate all through the building.

#### Commercial high rises without enough distribution transformers

Trying to cut corners in the wrong places; running 208 V feeder up twenty stories is not the road to PQ.

## Gen-sets not sized for harmonic loads

Excessive voltage distortion affects electronic control circuits. If SCR converter loads are present, notching can affect frequency control circuits.

### Applying PF correction capacitors without considering the effects of harmonics

Harmonics and caps don't mix. Those bulging capacitors are crying for help.

### Inrush currents from high torque motor loads started across-the-line

Causes voltage sags if the load is too large or the source impedance too great. Staggered motor starts can help.

### Undersized neutrals at panelboard

In the era of the 3rd harmonic, neutrals can easily carry as much current or more current than the phase conductor. Keeping them undersized leads to overheated lugs, potential fire hazards and high N-G voltage.

### Running power and signal cables together

Think of the signal cable as a single-wire transformer secondary and the power cable as the primary. The opportunities for coupling are endless.

### Loose conduit connections and lack of green wire grounding conductor

Causes open or high impedance ground circuit. Not good for PQ or safety.

### Shared neutrals on branch circuits

Causes load interaction and overloaded neutrals.

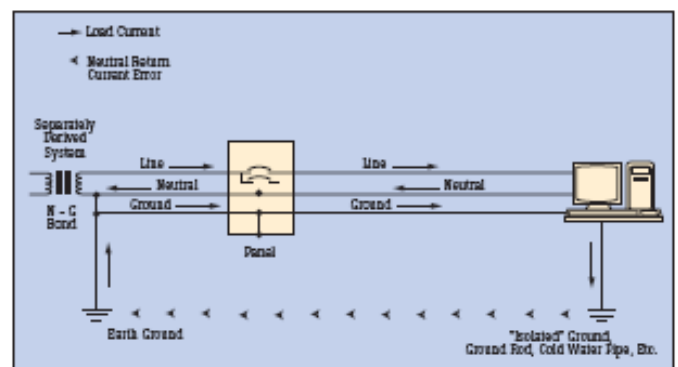

Figure 2 Isolated ground rod can cause ground loops. Common problem with CNC machine tool installations

## Laser printers and copiers sharing branch circuits with sensitive loads

Guaranteed periodic voltage sags and switching transients.

## Miswired receptacles (N-G swapped)

Hard to believe, but they are out there in quantity. Guaranteed to put return currents on the ground conductor and create a noisy ground.

## Data cables connected to different ground references at each end

Ouch! Shows up as voltage between equipment case and the data cable connector.

## Hi-frequency noise

The most effective high frequency grounding technique is the installation of a Signal Reference Grid (SRG).

## And in a class by themselves

### Isolated ground rods (below)

They're a safety hazard because the earth is a high impedance path and will prevent enough current from flowing to trip the breaker. They also cause ground loops; after all, every electron still has to go back where it came from. One of the great mysteries of PQ is how some manufacturers can insist that their equipment warranty is void unless an isolated ground rod is installed.

### Illegal N-G bonds

Guaranteed to put return currents on ground. Not only is it a PQ problem, it's a plumbing problem. Circulating ground currents cause corrosion of water pipes.

## International Safety Standards for Test Tools

Over-voltage Category	Summary Description
CAT IV*	Three-phase at utility connection, any outdoors conductor (under 1000V)
CAT III	Three-phase distribution (under 1000V), including single-phase commercial lighting and distribution panels
CAT II	Single-phase receptacle connected loads
CAT I	Electronic

\* CAT IV product specifications are not yet defined in the standard.

IEC 61010 establishes international safety requirements for low voltage (1000V or less) electrical equipment for measurement, control and laboratory use. The low voltage power distribution system is divided into four

categories, based on the proximity to the power source. Within each category are voltage listings—1000V, 600V, 300V, etc.

The key concept to understand is that you should use a meter rated to the highest category, as well as the highest voltage, that you might be working in. For PQ troubleshooters, that means a meter rated to CAT III 600 V or CAT III 1000 V (the specifications for CAT IV have not yet been defined by IEC). We recommend that you do not use CAT II rated meters, scopes or test leads and probes on CAT III circuits. The CAT ratings should be marked near the voltage inputs of the instrument. Meters designed to IEC 348, the previous standard, will typically not meet the more stringent safety specs of IEC 61010 CAT III 600/1000 V.

IEC 61010 requires increased protection against the hazards of transient over-voltages. Transients can cause an arc-over inside an inadequately protected meter. When that arc-over occurs in a high energy environment, such as a three-phase feeder circuit, the result can be a dangerous arc blast. The potential exists for serious harm to personnel as well as damage to the meter.

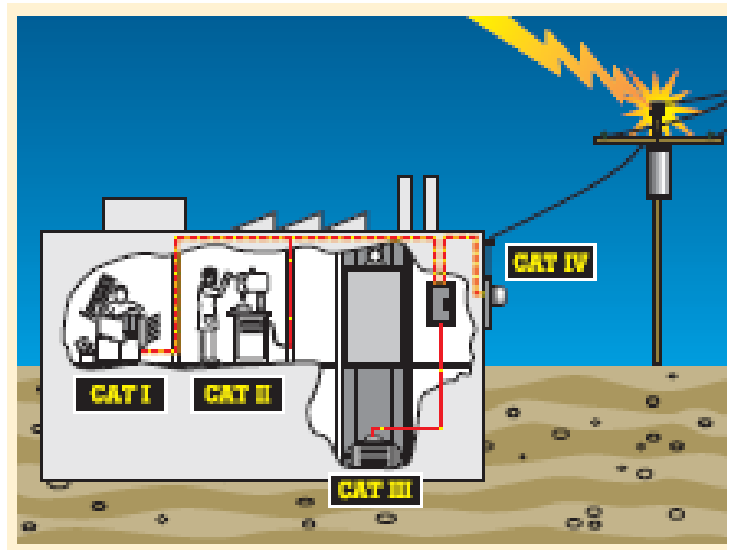

## Independent Testing and Certification

Manufacturers can self-certify that they meet IEC 61010 specs, but there are obvious pitfalls for the end-user in self-certification. Certification by an independent testing lab provides assurance that the meter meets IEC requirements. Look for a symbol and listing number of an independent testing lab such as UL, CSA, TÜV, VDE, etc. UL 3111, for example, is based on IEC 61010.